

NIDEK

NON-CONTACT TONOMETER

Model NT-2000 (MIII)

OPERATOR'S MANUAL

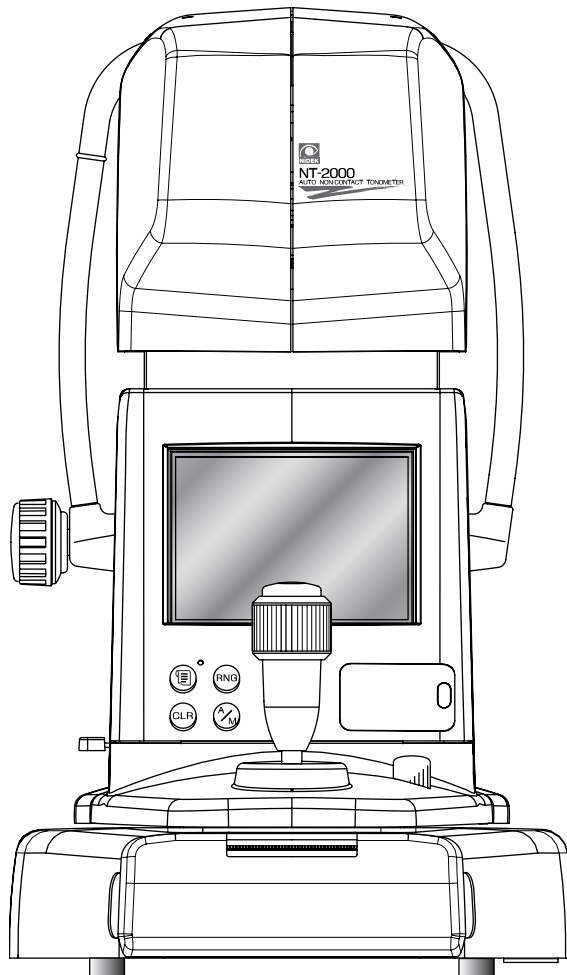



NIDEK CO., LTD.

NIDEK CO., LTD.
(Manufacturer)

: 34-14, Maehama, Hiroishi-cho, Gamagori, Aichi 443-0038, Japan
Telephone: (81-533) 67-6611
Facsimile: (81-533) 67-6610

NIDEK CO., LTD
(Tokyo Office)

: 3F Sumitomo Fudosan Hongo Bldg., 3-22-5, Hongo,
Bunkyo-Ku, Tokyo 113-0033, Japan
Telephone: (81-3) 5844-2641
Facsimile: (81-3) 5844-2642

NIDEK INCORPORATED
(United States Agent)

: 47651 Westinghouse Drive, Fremont, California 94539, U. S. A.
Telephone: (510) 226-5700
Facsimile: (510) 226-5750

NIDEK SOCIETE ANONYME
(EU Authorized Representative)

: Europarc 13, rue Auguste Perret, 94042 CRETEIL, France
Telephone: (01) 49 80 97 97
Facsimile: (01) 49 80 32 08

January 2008
18535-P932A
Printed in JAPAN



BEFORE USE OR MAINTENANCE, READ THIS MANUAL.



THIS MANUAL CONTAINS ONLY INFORMATION TO UNDERSTAND THE OPERATING PROCEDURES AND MAINTENANCE. TECHNICAL INFORMATION ABOUT THE INTRAOCULAR PRESSURE MEASUREMENT IS NOT INCLUDED.

This Operator's Manual contains the cautions for safety and operating procedures for the NIDEK NON-CONTACT TONOMETER Model NT-2000.

This manual complies with IEC 60601.

The cautions for safety and operating procedures must be thoroughly understood before using the instrument by reading this operator's manual. Keep this manual near the instrument for reference whenever necessary.

Use of the instrument is limited to the measurement of intraocular pressure by qualified physicians following the instructions in the operator's manual. The physicians are responsible for other applications of this instrument.

There are no user-serviceable parts inside the device except printer paper and fuses.

If you encounter any problems or have questions about the instrument, please contact NIDEK or your authorized distributor.



MEDICAL ELECTRICAL EQUIPMENT

34VK

UL60601-1

CAN/CSA C22.2 NO. 601.1

WITH RESPECT TO ELECTRIC SHOCK, FIRE AND MECHANICAL HAZARDS ONLY IN ACCORDANCE WITH UL60601-1 AND CAN/CSA C22.2 NO. 601.1

(This applies only to the equipments whose power source is 100/120VAC.)

[NOTE]

Words specific to this instrument are used in this operator's manual. These words are explained in the "Glossary" section near the end of this manual. See the table of contents for the glossary pages.

The "***" mark in this manual indicates that the word on the left is in the glossary. The "***" mark is attached to a word at every first appearance of it on a page.

CAUTION

- United States Federal law restricts this device to sale by or on the order of a physician.



Table of Contents

	Page
§1 INTRODUCTION	1-1
1.1 Outline	1-1
1.2 Principle	1-2
1.3 Indications for Use	1-2
1.4 Classifications	1-3
1.5 Symbol Information	1-4
§2 SAFETY PRECAUTIONS	2-1
2.1 In Storage, Transport, and Installation	2-1
2.2 In Wiring and Connection	2-4
2.3 In Use	2-5
2.4 After Use and During Maintenance and Checks	2-6
2.5 Disposal	2-7
2.6 Safety Functions	2-7
2.7 Labels	2-8
§3 SYSTEM DESCRIPTIONS	3-1
§4 OPERATING PROCEDURES	4-1
4.1 Operation flow	4-1
4.2 Measurement procedure	4-2
4.2.1 Basic measurement	4-2
4.3 Errors during Measurement	4-9
4.4 Setting and Operation of the Sub-switches	4-12
4.4.1 Eyelid detection mode	4-12
4.4.2 Test mode	4-13
4.4.3 Parameter setting mode	4-14
4.5 Cleaning of the Air Nozzle	4-19
4.5.1 Cleaning the air nozzle	4-19
§5 TROUBLESHOOTING GUIDE	5-1
5.1 Primary Troubles and the Countermeasures	5-1
5.2 Error Messages and the Countermeasures	5-2
§6 MAINTENANCE	6-1
6.1 Replacing the Printer Paper	6-1

	Page
6.2 Replacing the Fuses	6-3
6.3 Attaching the Chinrest Paper	6-4
6.4 Cleaning the Exterior	6-4
6.5 Consumables and Maintenance Parts List	6-4
§7 SPECIFICATIONS AND CONFIGURATION	7-1
7.1 Specifications	7-1
7.2 Standard Configuration	7-2
7.3 Options	7-2
GLOSSARY	Glossary-1

§1 INTRODUCTION

1.1 Outline

The NT-2000 is a non-contact tonometer to measure intraocular pressure by applanating** the cornea of the patient's eye using air pressure for early detection of glaucoma, post-operative care, and such in ophthalmology.

This instrument is comprised of the main unit, the measuring unit, and the base unit. The former two units are on top of the base unit. On the base unit, the chinrest and the printer are provided. On the main unit, the screen, the control panel and the joystick are provided. On the measuring unit, the air-nozzle and the photo-sensor are provided.

The NT-2000 has the following features:

1. Auto-alignment mode

When the measuring unit approaches the center of the pupil in this mode, the instrument automatically performs alignment** in the up, down, left, and right directions. Then an optimal distance between the patient's eye and the instrument for focusing is obtained by moving the instrument forward and backward using the joystick. After that, the measurement starts automatically. Therefore, operators who use the instrument for the first time can use it easily and obtain stable measurement data without differences in alignment among operators.

2. APC (Automatic Puff Control) function**

The intraocular pressure measurement can be performed using minimal air pressure.

When the measurement range** is set to "APC 40" or "APC 60", in the first measurement, the automatic shut-off function**, which is to stop puffing air as soon as the light reflected from the cornea is detected, activates in order to eliminate excessive puffing. In subsequent measurements, the APC function activates to perform the measurement with the minimum air pressure based on the former measurement data. As the patient's eye is protected from excessive air pressure, patient discomfort can be decreased and continuous measurement can be performed smoothly.

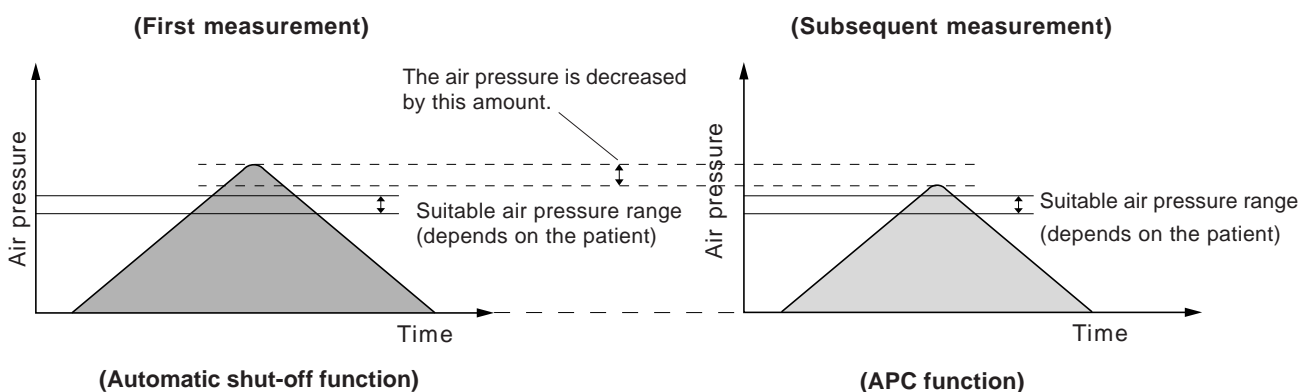

The NT-2000 is equipped with the above two features for obtaining stable measurement data and achieving smooth measurement.

1.2 Principle

According to Imbert-Fick's law, when a sphere which has internal pressure (P_t) is applanated** by a strength (W), the formula, " $W = P_t \times A$ " holds as the relation between the flattened surface (A), W , and P_t . The intraocular pressure (P_t) can be obtained by measuring the strength (W) under the condition that the degree of flatness (A) is stable. Generally, applanation tonometers like the Goldmann type use this principle.

The NT-2000 increases the air pressure puffed out** onto the cornea in proportion to time. The shape of the cornea changes gradually in the order of convex surface \rightarrow applanated surface \rightarrow concave surface. This change is optically detected and the instrument calculates the time (t) required to make the pressed area (A) flat after puffing out air. The intraocular pressure is calculated from the relationship between the time (t) and the pressure at the time of applanation.

The flatness of the cornea is detected by monitoring the amount of the reflection of the light transmitted from the phototransmitter to the cornea. From an undisturbed cornea, little or no light is captured by the photodetector. When the cornea is applanated, the light reflected from the cornea travels in the same direction and the photodetector receives the maximum amount of the light. By this method, the applanated state of the cornea is detected.

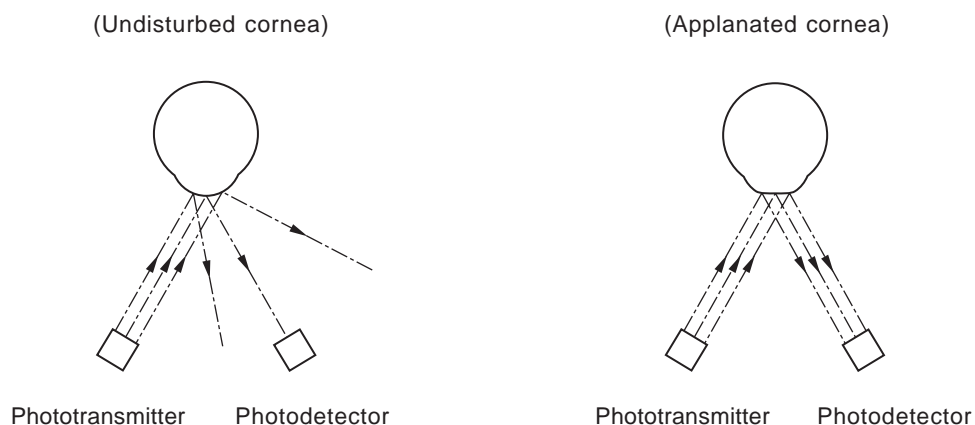

Therefore, if the eye is not opened wide enough during measurement, the applanation of the cornea may become imperfect because the puffed air is prone to be interrupted by the eyelid and eyelashes. Also the applanated state of the cornea may not be detected properly because the light is blocked. As reliable measurement data may not be obtained under such a condition, pay special attention to how wide the eye is opened.

1.3 Indications for Use

The Nidek Model NT-2000 is a non-contact tonometer that is indicated for use in the measurement of intraocular pressure of the human eye.

1.3 Classifications

[Protection method against electric shock] Class I

The NT-2000 is classified as a Class I instrument.

A Class I instrument is an instrument in which protection against electric shock does not rely on basic insulation only, but which includes an additional safety precaution in such a way that means are provided for the connection of accessible conductive parts to the protective (earth) conductor in the fixed wiring of the installation in such a way that accessible conductive parts cannot become live in the event of a failure of the basic insulation.

[Degree of protection against electric shock] Type B applied part

The NT-2000 is classified as a system with a Type B applied part.

A system with a Type B applied part provides an adequate degree of protection against electric shock particularly regarding;

- allowable leakage currents
- reliability of the protective earth connection (if present).

[Degree of protection against ingress of liquids] IP20

The NT-2000 is an ordinary instrument (enclosed instrument without protection against an ingress of liquids). Be careful not to expose water to the instrument.

[Degree of safety in the presence of flammable anesthetics and/of flammable cleaning agents]

The NT-2000 should be used in environments where no flammable anesthetics and/or flammable cleaning agents are present.

[Method(s) of sterilization or disinfection recommended by the manufacturer]

The NT-2000 does not have any parts to be sterilized or disinfected.

[Mode of operation]

The NT-2000 is a continuous operating instrument.

[Classification by transportability]

The NT-2000 is classified as a transportable instrument.

1.4 Symbol Information



This symbol indicates that reference to the operator's manual is necessary prior to operation and maintenance.



This symbol indicates that the degree of protection against electric shock is for a Type B applied part.



The symbol indicates the state of the power switch. When the switch is pressed to the side of this mark, the power is ON.



The symbol indicates the state of the power switch. When the switch is pressed to the side of this mark, the power is OFF.



This symbol indicates the fuse rating.



This symbol indicates that the system shall be operated only with an alternating current.



Indicates the date of manufacture.





Indicates the manufacturer.

§2 SAFETY PRECAUTIONS

In this manual, Signal Words are used to designate a degree or level of safety alerting. The definitions are as follows.

 **WARNING:** Indicates a potentially hazardous situation which, if not avoided, could result in death or serious injury.

 **CAUTION:** Indicates a potentially hazardous situation which, if not avoided, may result in minor or moderate injury or a property damage accident.

Some items described in  **WARNING** and  **CAUTION** may cause a serious accident depending on the circumstances. Follow all the instructions mentioned below since they are very important.

2.1 In Storage, Transport, and Installation

CAUTION

- The place for storing and installing and the environment during transport of the instrument need to satisfy the following conditions:
 - The instrument is not exposed to direct sunlight or ultraviolet rays.
 - The instrument is not exposed to rain or water.
 - Neither chemical agents nor organic solvents are stored.
 - There is no salt, sulfur content, toxic gas or large amounts of dust in the air.
 - The place should be vibration and shock-free, level and stable.
 - A place where the following environmental conditions for storage, transport (= packed condition) and installation (=unpacked condition) are satisfied:
 - <Storage and transport> ... Temperature: -20 to 60°C (-4 to 140 °F)
Humidity: 10 to 95% (non-condensing)
 - <Installation> Temperature: 10 to 40°C (50 to 104 °F)
Humidity: 30 to 85% (non-condensing)
- Before transport, move the measuring unit to the lower limit and lock the main unit to the base. Failure to do so may cause the measuring unit to move during transport and the instrument to malfunction.
- Never trail the power cord while it is connected to the instrument during transport. The instrument may fall and that may cause injury and malfunction if the cable is stepped on or pulled.

 **CAUTION**

- Hold the base of the instrument, not the forehead rest or the chinrest, from the sides for transport. Otherwise, the forehead rest and chinrest may be deformed or damaged.
- Avoid installing the instrument where the instrument is exposed to direct air-conditioning flow. Changes in temperature may cause condensation in the instrument and affect sensitivity of the sensor and the measurement results.
- Install the instrument where direct sunlight or scattered light do not come from the air nozzle side.
The measurement may be affected because of failure of pupil detection, etc..
- In installation and operation of the device, observe the following instructions about EMC (electromagnetic compatibility):
 - Do not use the device simultaneously with other electronic equipment to avoid electromagnetic interference with the operation of the device.
 - Do not use the device near, on, or under other electronic equipment to avoid electromagnetic interference with the operation of the device.
 - Do not use the device in the same room with other equipment such as life-support equipment, other equipment that has major affects on the life of the patient and results of treatment, or other measurement or treatment equipment that involves small electric current.
 - Do not use the device simultaneously with portable and mobile radio frequency communication systems because it may have an adverse effect on operation of the device.
 - Do not use cables and accessories that are not specified for the device because that may increase the emission of electromagnetic waves from the device or the system and decrease the immunity of the device to electromagnetic disturbance.

! CAUTION

- The patient environment is the volume of space in which contact can occur between the patient and any part of the device (including connected devices) or between the patient and any other person(s) touching the device (including connected devices).

Use devices that comply with IEC60601-1 in the patient environment. If any device that does not comply with IEC 60601-1 is to be used, use an isolating transformer or common protective grounding.

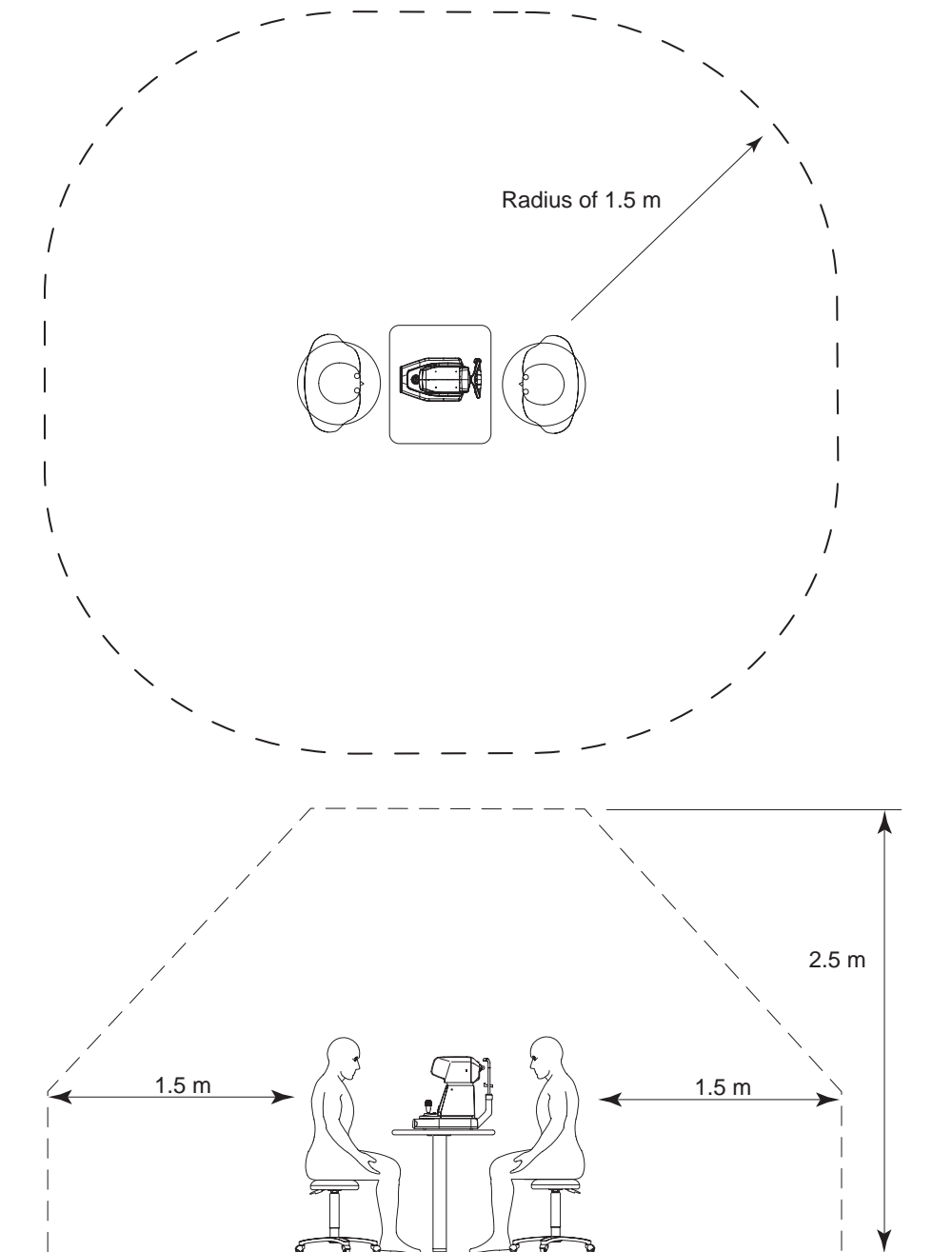

2.2 In Wiring and Connection

CAUTION

- Connect the power cord to a grounded wall outlet which meets the power requirements specified on the label on the instrument.
Otherwise, the system may not perform sufficiently or may be damaged.
- Be sure to use a (HOSPITAL GRADE) wall outlet equipped with a grounding terminal in order to avoid electric shock or fire in the event of power leakage.
- Avoid a starburst connection.
The system may not perform sufficiently and a fire may occur.
- Always pull the plug, not the cord, when plugging and unplugging the power cord.
If the core wire of the cord breaks, it may cause a fire or electric shock from a short-circuit.
- Do not to let the power cord get pressed under heavy objects such as the instrument or get pinched.
The cable sheath may break, and a short-circuit or electric shock may result.
- If the core wire of the power cord is exposed, do not continue using the power cord. Unplug the power plug and contact NIDEK or your authorized distributor.
Continued use of a broken power cord may cause an electric shock or fire.
- Be careful not to let dust accumulate on the plug of the power cord.
If dust accumulates, it absorbs moisture and may cause a short-circuit and a fire.
- Install the instrument in a place where there is no device such as a laser system which generates strong electromagnetic waves.
There may be a case where correct measured values cannot be obtained due to the influence of the strong electromagnetic waves. Where the instrument is installed in a place with such devices, stop their operation, and then start measurement.
- Do not use any power cord other than the one supplied.
Also do not connect the supplied power cord to any other device.
Failure or fire may result.

2.3 In Use

WARNING

- Before starting the measurement, be sure to set the safety stopper for each patient to prevent the air nozzle from touching the patient's eye.
If the air nozzle touches the eye, the cornea may be damaged.

CAUTION

- Use this instrument only for measuring intraocular pressure.
NIDEK assumes not responsibility for accidents caused by using the instrument for other than the measurement of intraocular pressure.
- In the event of trouble, unplug the power plug and contact NIDEK or your authorized distributor without touching the inside of the instrument.
- Do not modify or touch the inside of the instrument.
An electric shock or malfunction may occur.
- In measurement using the auto alignment, the measuring unit automatically moves in the up, down, right, and left directions. Do not place fingers between the measuring unit and the main unit.
Fingers may be pinched and get injured.
- In advance of measurement of each patient, wipe the forehead rest and chinrest that contact the patient with clean absorbent cotton or gauze dampened with rubbing alcohol.
If the chinrest paper is used, remove one piece for each patient.
- Do not let dirt such as fingerprints, dust, etc. get on the observation window around the air nozzle.
The accuracy of the alignment decreases and, as a result, the measurement value is affected.
- This device uses a heat-sensitive printer paper. To keep the printed data for a long period of time, make copies of the printouts.
The paper degrades over time and the printed data may become illegible.

NOTE

- A pixel may be rarely missing on the screen or a red, blue, or green pixel point may always be displayed.
It depends on the structure of the LCD, and is not a failure.

2.4 After Use and during Maintenance and Checks

CAUTION

- After using the instrument, turn OFF the power and put the dust cover on the instrument. Accumulated dust may make the eye to be measured unsanitary and such a condition may affect the accuracy of the measurement.
- When the instrument will not be used for a long time, unplug the power plug from the wall-outlet.
If dust is accumulated on the power plug, it absorbs moisture and may cause a short circuit or a fire.
- Take care not to damage or soil the observation window around the air nozzle with scratches, finger prints, dust, etc..
The accuracy of the alignment decreases and measurement results will be affected.
- Do not use organic solvents (thinner, etc.) or cleaners containing abrasives.
The surface and paint of the housings may be damaged.
- Use the specified fuses.(See “**6.5 Consumables and Maintenance Parts List**” p.6-4.)
Otherwise, the instrument may malfunction and a fire may occur.
- Use the printer paper specified by NIDEK. Replace it following the procedure described in “**6.1 Replacing the Printer Paper**” (p. 6-1).
Otherwise, jamming of the paper or failure of printing may occur.
- When the instrument is sent back to NIDEK for repair or maintenance, wipe the surface (especially, the area where the patient’s skin contacts) of the instrument with a clean cloth immersed in ethyl alcohol for disinfection.



2.5 Disposal

CAUTION

- Follow local governing ordinances and recycling plans regarding disposal of the instrument. The circuit board includes lithium batteries. The disposal method varies according to the local government. Check the specified disposal method for a specific waste in advance.
- When disposing of packing materials, sort them by material and follow local governing ordinances and recycling plans.

2.6 Safety Functions

[Safety stopper]

For safety, this stopper provides a safety space** so that the air nozzle does not touch a patient's eye during measurement.

The amount of space needed for safety depends on the patient. Change the position of the stopper for each patient to ensure the proper amount of space for safety.

2.7 Labels

In order to catch the user's attention, the appropriate warning labels are attached to the specified locations on the instrument.

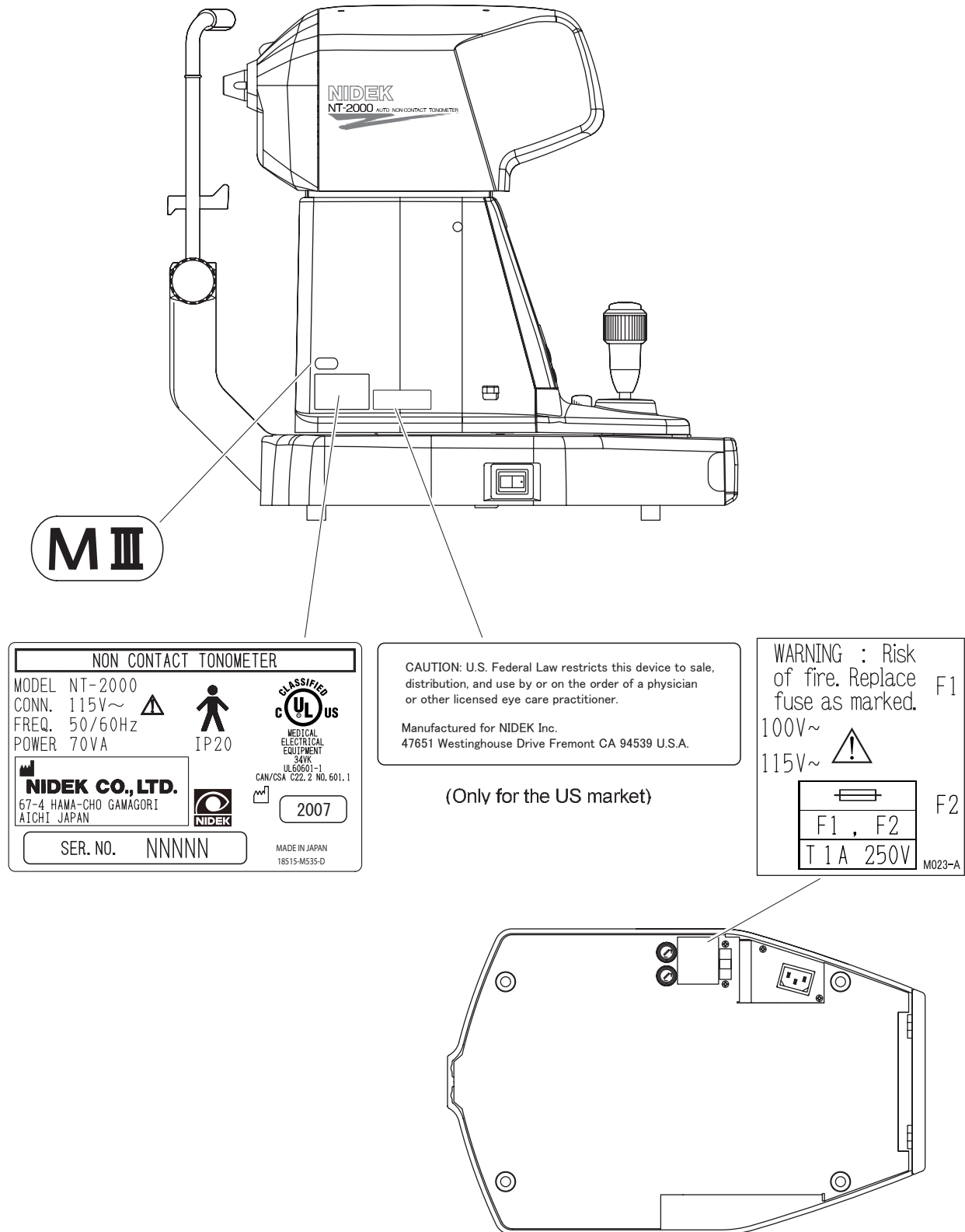

§3 SYSTEM DESCRIPTIONS

[Operator's side]

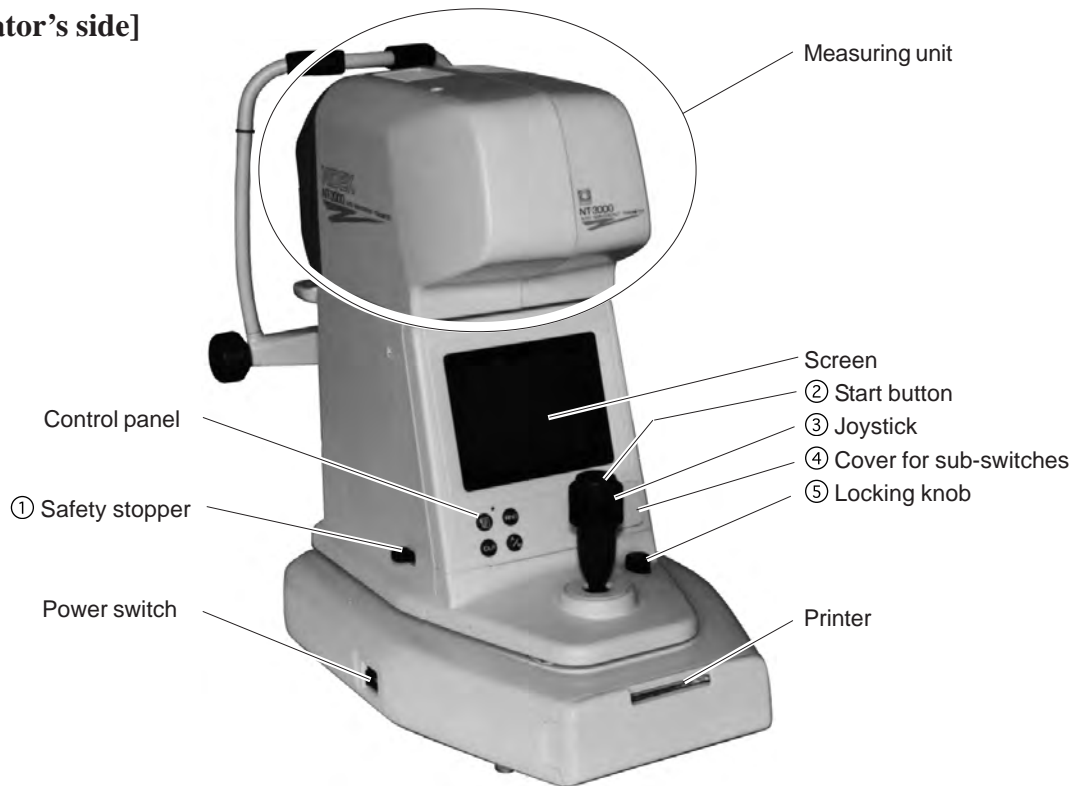

[Patient's Side]

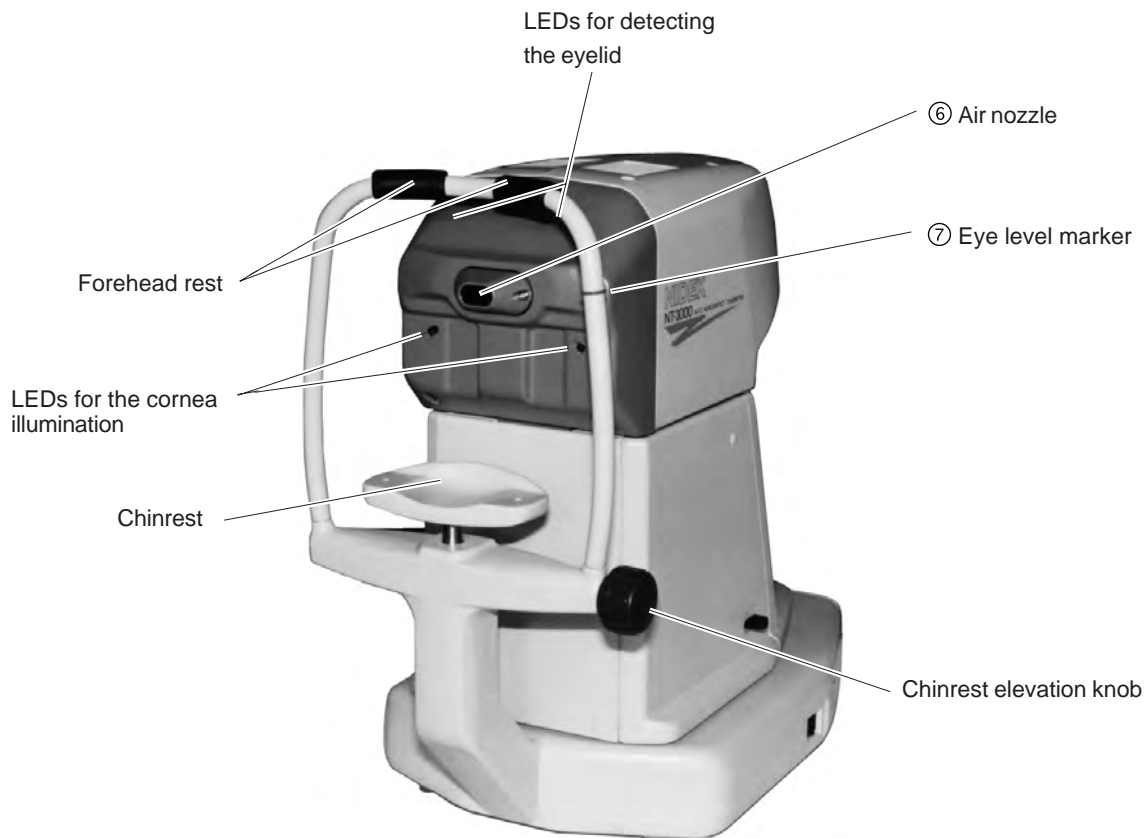

[Operator's Side]**① Safety stopper**

Used to provide a safety space** so that the air nozzle does not touch the patient's eye. Change the position of the stopper for each patient to keep the proper amount of space for safety.

* When the safety stopper is locked, a click is heard and the stopper returns to the up position. After that the measuring unit returns to the original position in the right, left, front and back directions automatically.

② Start button

When this button is pressed during the measurement, air is puffed out** and the measurement starts regardless of the alignment** and focusing** conditions. When this button is pressed in the TEST mode**, air is puffed out.

③ Joystick

Used for alignment and focusing**. Alignment in the right and left directions can be performed by moving the joystick to the right and left. Rotating the joystick is for alignment in the up and down directions. For focusing, move the joystick back and forth.

④ Cover for sub-switches

Under this cover, there are switches for selecting the modes, etc.. Press the right side of the cover lightly to open the cover.

⑤ Locking knob

Used to fix the main unit to the base unit. To fix the main unit at the center of the base unit, turn the knob in the LOCK direction while pressing it. To fix the main unit to a desired position temporarily, turn the knob in the BRAKE direction.

[Patient's side]**⑥ Air nozzle**

Puffs out air.

* The "air nozzle" described in this manual includes the observation window around the nozzle.

⑦ Eye level marker

The outward ends of the patient's eyes are aligned using this marker.

NOTE

- Materials composed of parts that contact the patient during measurement are as follows:
 - Forehead rest: Polyvinyl chloride resin
 - Chinrest: ABS resin

[Bottom View]

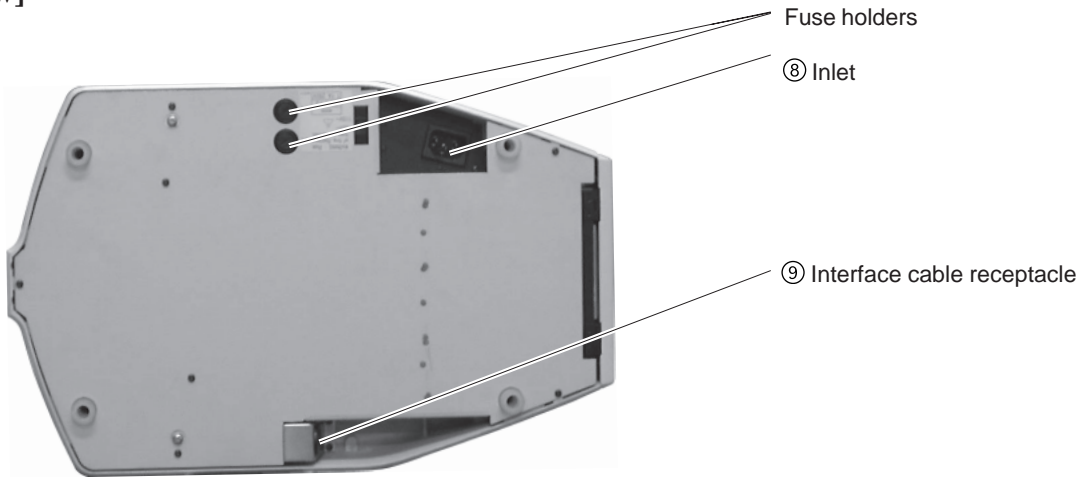

[Control Panel]

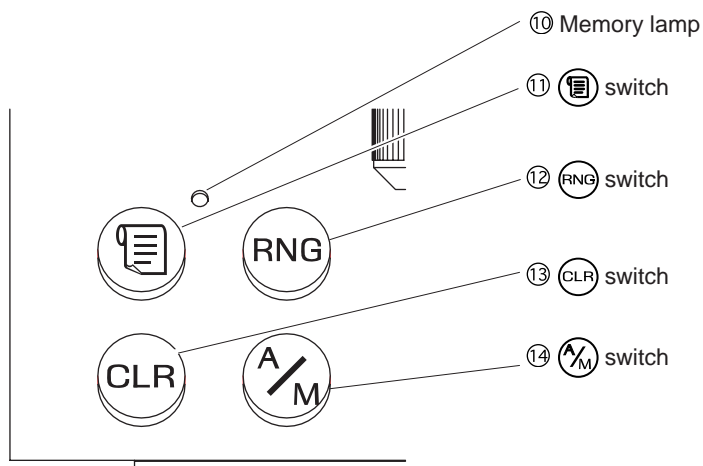

[Sub-switches]

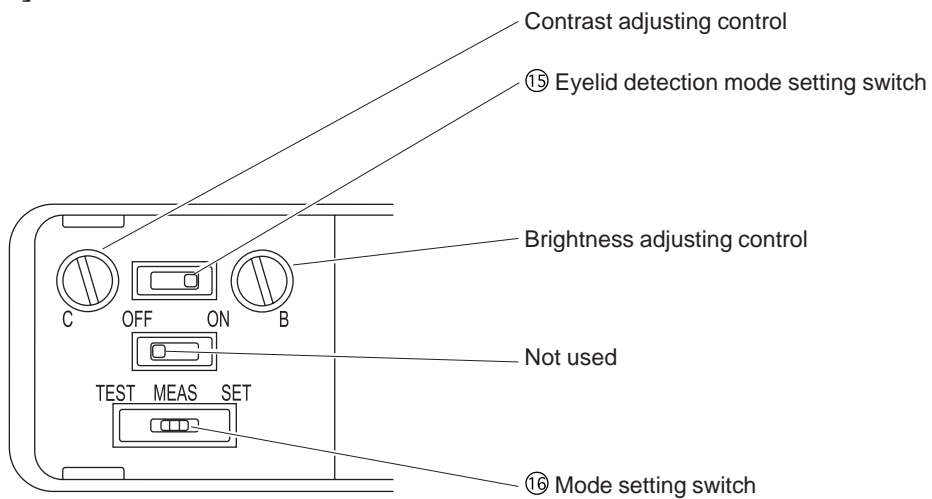

[Bottom View]**⑧ Inlet**

The power cable is inserted here.

⑨ Interface cable connector

Used to connect the interface cable that is needed for sending measurement data to an external computer.

Accessory equipment connected to the analog and digital interfaces must be certified according to the representative appropriate national standards (for example, UL 1950 for Data Processing Equipment UL 2601-1 for Medical Equipment, and CSA C22.2 No. 601-1, EN 60601-1 and IEC 60601-1.)

Furthermore, all configurations shall comply with the system standard IEC 60601-1-1. Anybody who connects additional equipment to the signal input or signal output parts configures a medical system, and is therefore responsible that the system complies with the requirements of the system standard IEC 60601-1-1. If in doubt, consult the technical service department or your local representative.

[Control Panel]**⑩ Memory lamp**

Lights up when the measurement data that can be printed out are saved.

⑪  switch

If this switch is pressed when the memory lamp is lit, the measurement data are printed out. If this switch is pressed when the memory lamp is not lit, the printer paper is advanced. After the printout, the measuring unit returns to the original position in the up, down, right, left, front, and back directions automatically.

⑫  switch

Used to select the measurement range**. Every pressing of this switch changes the measurement range in the order of “APC 40” → “APC 60” → “40” → “60” → “APC 40”....

* When the power switch is turned ON, the initial setting is “APC 40”.

⑬  switch

Used to clear the measurement data. When this switch is pressed, all the measurement data are deleted and the measuring unit returns to the original position in the up, down, right, left, front, and back directions automatically.

⑭  switch

Used to select the alignment mode**. Every pressing of this switch changes the alignment mode in the order of “AUTO” → “MANUAL” → “AUTO”....

* When the power switch is turned ON, the initial setting is “AUTO” mode.

[Sub-switches]**⑮ Eyelid detection mode setting switch**

Sets the detection (eyelid detection) mode** which detects whether the eyelid is over the applanation area or not.

ON side The detection is set.

OFF side The detection is cancelled.

When the mode is cancelled, “” appears on the right of the alignment mode indication on the screen.

* For detailed information, see “4.4.1 Eyelid detection mode” (p. 4-11).

⑯ Mode setting switch

Used to select from the following modes.

Center (MEAS)

..... Measurement mode (normal)

Right (SET) . Parameter setting mode

Left (TEST) . TEST mode**

* For the details, see “4.4.2 Test mode” (p. 4-12) and “4.4.3 Parameter setting mode” (p. 4-13).

[Screen]

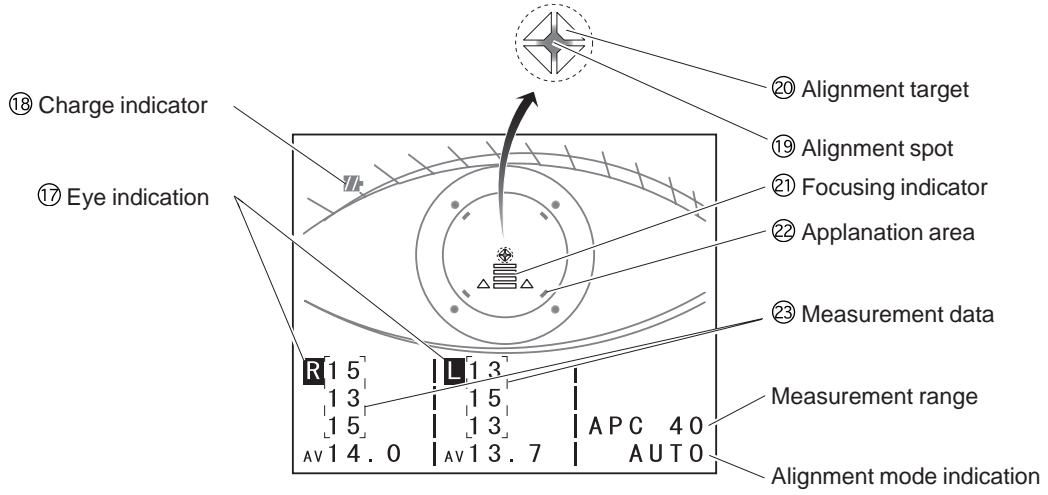

[Screen]**⑰ Eye indication**

The indication (either “R” (right) or “L” (left)) of the eye to be measured blinks.

⑱ Charge indicator

Indicates that the system is in the standby mode for the puffing out** of air. While it is indicated, air cannot be puffed out.

⑲ Alignment target ()

The target to bring the patient’s eye to the center of the screen.

⑳ Alignment spot

The spot appears on the patient’s eye by light emission.

Perform alignment** in the up, down, right, and left directions to bring this spot to the center of the alignment target.

㉑ Focusing indicator**

Shows the distance between the patient’s eye and the air nozzle.

Operate the joystick until you can obtain the proper alignment** ().

㉒ Applanation area ()

Means the range in which air is puffed out to the cornea.

㉓ Measured data

Three measured values are shown. The newest measured value is shown at the top and the older values are at the bottom.

* The “AV...” are the averages. If a highlighted number appears on the right of the average value, it indicates the number of measured values used to calculate the average.

§4 OPERATING PROCEDURES

4.1 Operation flow

The following is the basic operation flow.

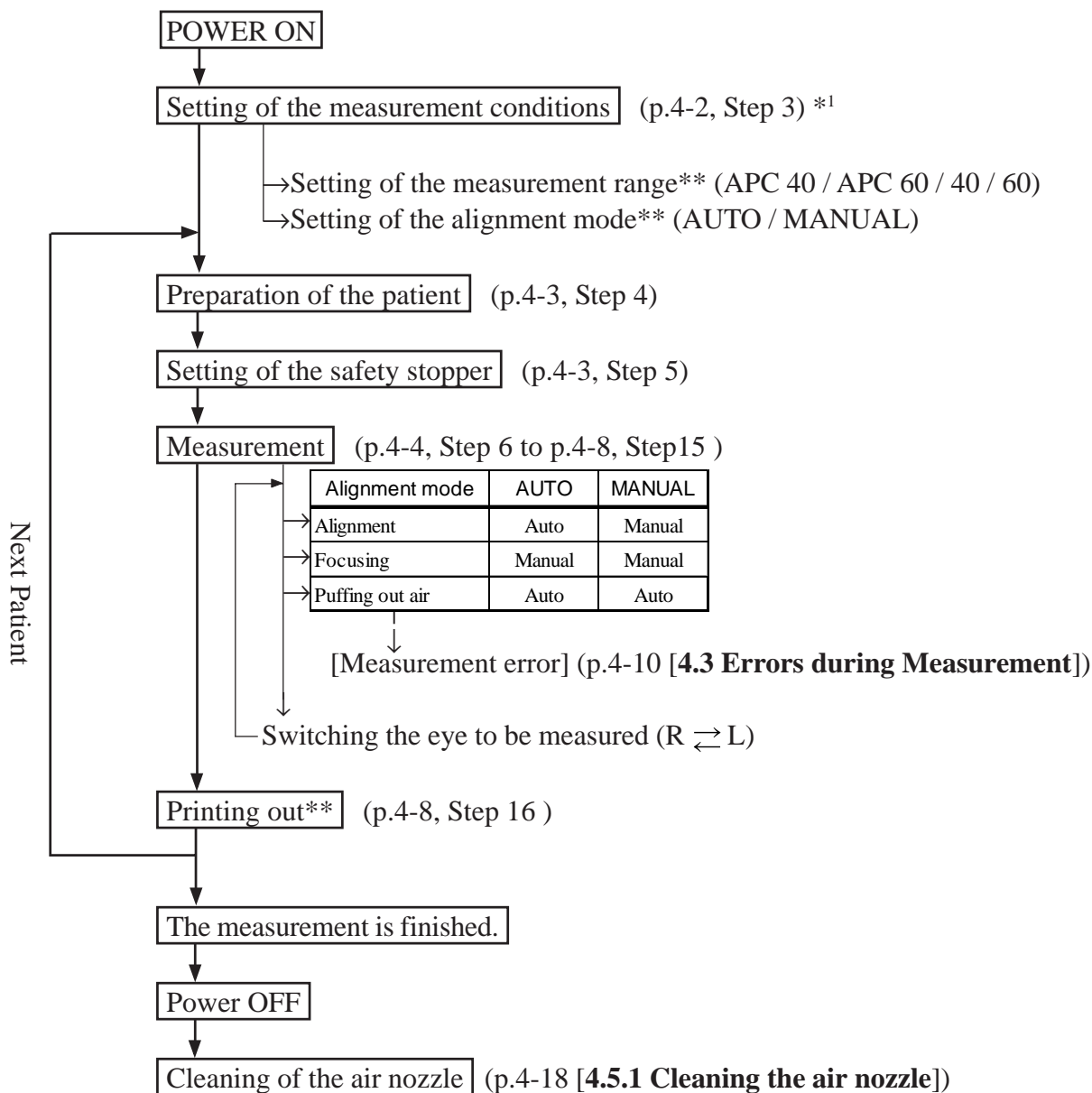

*1 As for the modes that are not in the operating flow above, see the following pages:

- Eyelid detection mode** p. 4-12.
- Test mode** p. 4-13.
- Parameter setting mode p. 4-14.

4.2 Measurement procedure

4.2.1 Basic measurement

The basic measurement procedure is explained here.

1. Turn ON (|) the power switch.

The indications as in the figure on the right appear on the screen.

* The indication of the eyelid detection mode** appears if those modes are set beforehand with the sub-switches. For the setting, see “4.4 Setting and Operation of the Sub-switches” (p. 4-12).

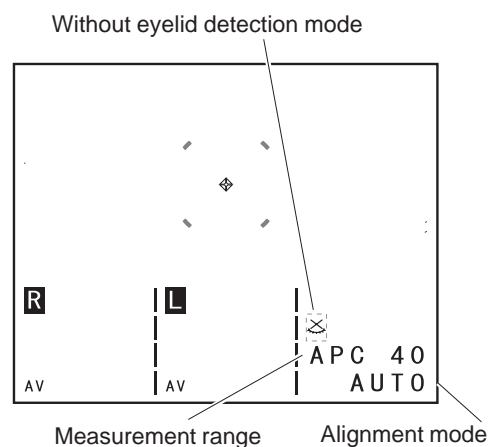

2. Check the instrument before use. (Check the following items for any abnormality.)

- The indication explained in Step 1 above is on the screen.
- No dust or contamination on the air nozzle.
- No abnormal sound is heard.
- The joystick moves smoothly.

3. Change the measurement range** and the alignment mode**.

- 1) Press the (RNG) switch to select the measurement range. Every pressing of this switch changes the measurement range in the order of “APC 40” → “APC 60” → “40” → “60” → “APC 40” ...

* When the power switch is turned ON, the initial setting is “APC 40”.

Measurement range	Standard for selection	Control of the air pressure
APC 40	Normal	Peak of the air pressure is automatically controlled within the range of 1 to 40 mmHg.
APC 60	40 mmHg or more of intraocular pressure	Peak of the air pressure is automatically controlled within the range of 1 to 60 mmHg.
40	Intraocular pressure fluctuates remarkably.	Peak of the air pressure is fixed within the range of 1 to 40 mmHg.
60	40 mmHg or more of intraocular pressure that fluctuates remarkably.	Peak of the air pressure is fixed within the range of 1 to 60 mmHg.

- 2) Press the (A/M) switch to select the alignment mode. Every pressing of this switch changes the alignment mode in the order of “AUTO” → “MANUAL” → “AUTO” → ... (When the power switch is turned ON, the initial setting is “AUTO” mode.)

Alignment mode	Alignment (vertical/horizontal)	Focusing (back and forth)
"AUTO"	Auto	Operation by joystick
"MANUAL"	Operation by joystick	Operation by joystick

4. Prepare the patient for measurement.

- 1) Wipe the forehead rest and chinrest that contact the patient with clean absorbent cotton or gauze dampened with rubbing alcohol.
 - * If the chinrest paper is used, remove one piece for each patient.
- 2) Have the patient remove contact lenses or glasses and sit on the chair.
- 3) Have the patient place his/her chin on the chinrest as deeply as possible, and his/her forehead on the forehead rest lightly.
- 4) Align the patient's eyes with the eye level marker by turning the chinrest elevation knob.



5. Set the safety space** between the patient's eye and air nozzle with the safety stopper.



WARNING

- Before the measurement, be sure to set the safety stopper.
The air nozzle may touch and scratch the cornea.

- 1) Pressing the safety stopper*², operate the joystick so that the air nozzle approaches the cornea slowly.
- 2) While watching from the left side of the instrument, release the stopper when the space between the patient's eye and the air nozzle becomes 7 to 8 mm.

Safety stopper

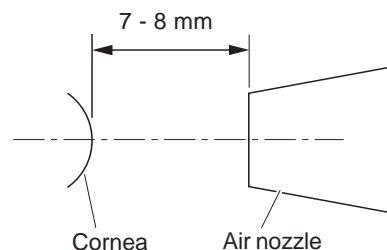
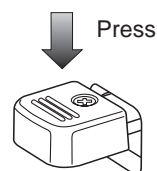

The safety stopper returns to the up position and makes a click sound when it locks the main unit to the determined position.

- 3) Slightly move the joystick back and forth to confirm that the main unit does not move beyond the locked position set in step 2).

*² While the safety stopper is being pressed, "RTN TO ORG" (Return to origin) appears on the screen. At this time, the alignment** is not performed automatically in spite of the setting of "AUTO". In addition, the instrument does not puff out** air even if the proper alignment** is obtained.

6. Explain the measurement to the patient.

To help the patient relax, make an explanation like the following one to the patient before starting the measurement:

((Example))

“You may be surprised by air puffed into your eye, but do not worry. Please be patient and relax for a moment until I can measure your intraocular pressure three times per each eye.”

7. Move the joystick in the front, back, right and left directions, and rotate it to get a clear eye image in the center of the screen.

8. Instruct the patient to look at the fixation light (green LED)*3 in the air nozzle.

NOTE

- Confirm that the eyelashes and eyelid are not in the applanation area () and confirm that the eye is not watery.

These factors cause measurement errors or decrease the accuracy of measurements. If the eyelashes and eyelid are in the applanation area, help raise them. If the eye is watery, have the patient blink his/her eyes or wipe the tears.

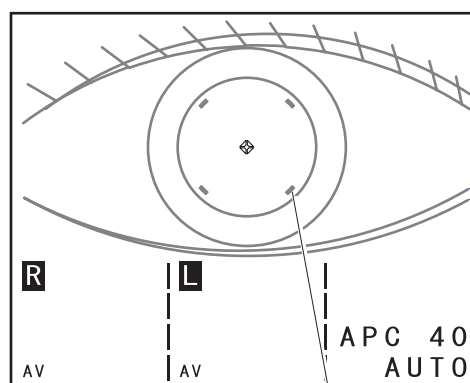

Applanation area

*3 It can be selected whether to make the green LED blink or light continuously by changing the parameter setting. For details, see “9. FIX LED BLINK” (p. 4-16).

9. Perform alignment** to the eye to be measured.

[In the case of “AUTO”]

Alignment in the up, down, right, and left directions is automatically performed.*4

NOTE

- Auto-alignment is performed only when the patient’s eye is being displayed on the screen. If the auto-alignment cannot be performed, operate the joystick to display the patient’s eye on the screen.
- If the range for auto-alignment is exceeded, arrows (◀ or ▶: limit of the horizontal movement, ▲ or ▼: limit of the vertical movement) appear.
In the case of the arrows ◀ or ▶, tilt the joystick in the direction of the arrow to make the arrow disappear.
In the case of the arrows ▲ or ▼, the arrow ▲ indicates that the patient’s eye is too low in relation to the measuring unit, and the arrow ▼ indicates that the patient’s eye is too high in relation to the measuring unit. In both cases, move the chinrest in the direction of the arrow to make the arrow disappear.

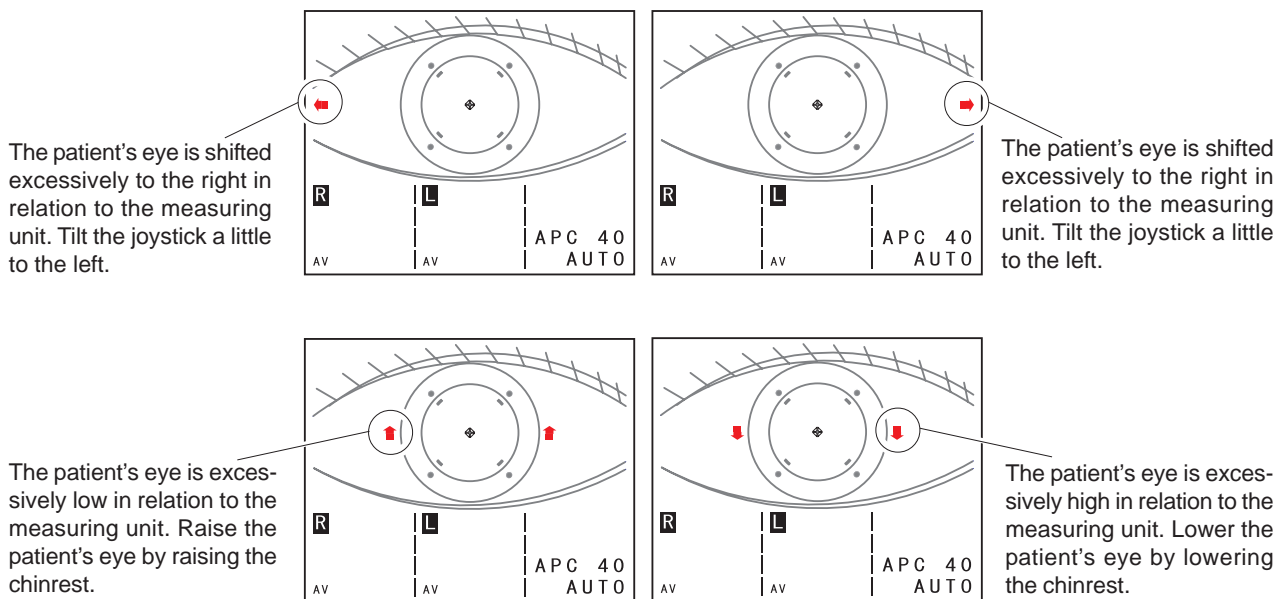

[In the case of “MANUAL”]

Bring the alignment spot inside the alignment target by moving the joystick to the right and left or rotating it.

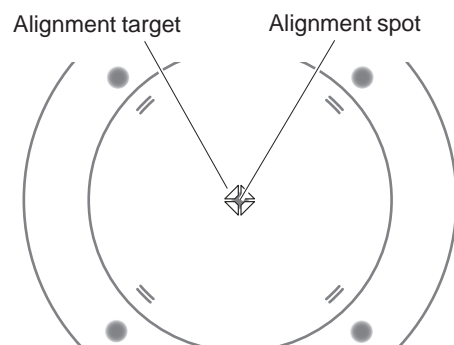

10. Adjust the focusing on the eye to be measured.**

While keeping the alignment, move the joystick back and forth to change the focusing indicator** to the proper alignment** “”.

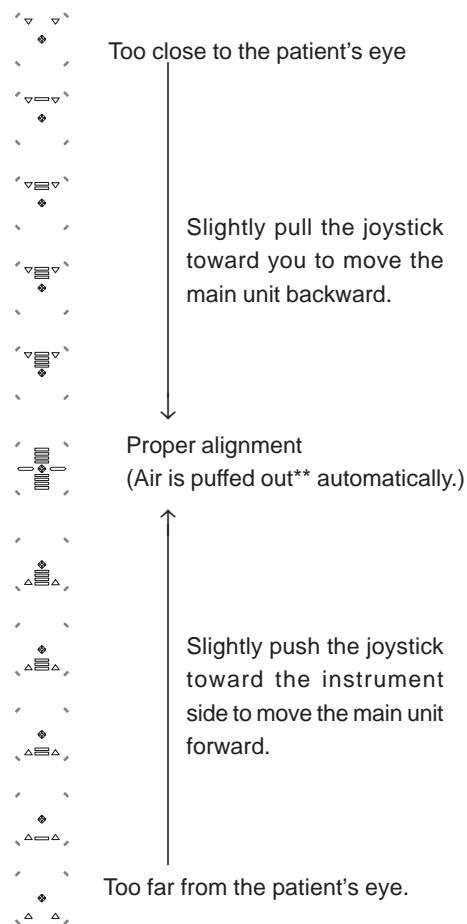
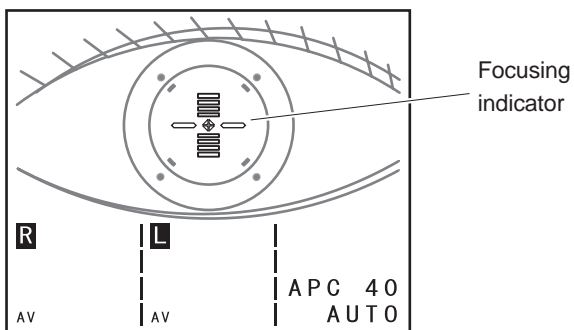

11. When the focusing indicator** maintains the proper alignment**, the measurement starts.

Air is puffed out** automatically and the measurement starts.

* The condition for the start of the measurement may differ according to the selected measurement mode.*⁴

NOTE

- Air is puffed out automatically when the alignment mode is “AUTO” or “MANUAL”.
- To obtain accurate measurement data, perform the measurement under the condition that the eye is opened wide enough, eye fixation is proper, and the patient’s posture is stable.
- In some cases, the air is puffed out while the eye is blinking. In this case, accurate measurement data cannot be obtained and the patient will feel uncomfortable. Therefore, pull the joystick toward you and hold it until the eye stops blinking.
- If the alignment spot cannot be displayed sharply on the cornea because of scratches on the cornea, etc., **the instrument may not start measurement even when the proper alignment and focusing** is obtained.** Even in such a case, **measurement can be performed by pressing the start button.**

12. The measurement data appears on the screen.

The measurement data and average appear on the screen.

After air is puffed out, the charge indicator appears for several seconds to indicate that the instrument is in the standby mode.

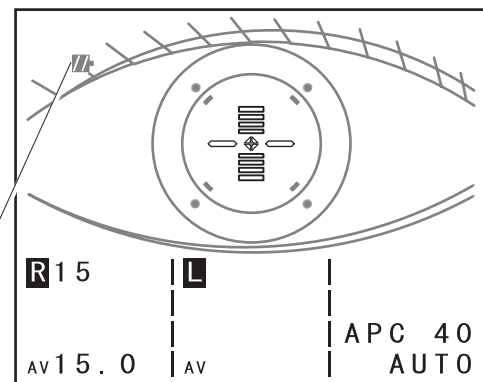

Charge indicator

NOTE

- If the measurement is not performed correctly for some reason, an abbreviated error message appears on the top right of the measurement range** alignment mode indication. In this case, eliminate the cause of the error and perform the measurement again. (For the details, see “**4.3 Errors during Measurement**”. (p. 4-10))

*⁴ The eyelid detection mode** can be selected for the NT-2000 to judge the proper alignment to obtain accurate measurement values automatically. For the detail, see “**4.4.1 Eyelid detection mode**” (p. 4-12).

13. Repeat steps 9 to 12 and measure the intraocular pressure three times or more.*5

14. Pull the joystick toward you once and move the main unit to the other eye.

The indication of the eye toward which the joystick has been moved blinks. The measuring unit returns to the original position.*6

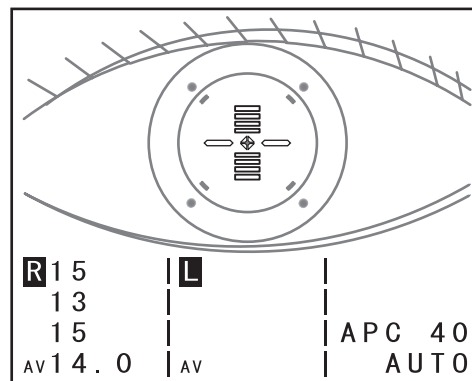

15. Measure the intraocular pressure of the other eye in the same way as steps 7 - 13.

16. Press the  switch to print out the measured data.

After printing, the measurement data are cleared and the memory lamp is turned OFF. Then the measuring unit returns to the original position.*6

NOTE

- Only when the memory lamp is lit, is printing out possible.

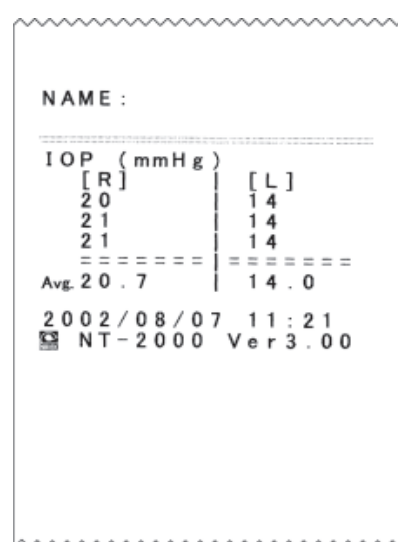

*5 Intraocular pressure fluctuates with the patient's pulse and breath. As the non-contact tonometer measures the intraocular pressure of an instant, it is general to regard the average of the three or more measured values as the intraocular pressure.

*6 The measuring unit returns to the original position not only when the measured values are printed out, but also in the following cases:
(When the measuring unit returns to the height of the eye level marker, "RTN TO ORG ALL" is indicated.)

<"RTN TO ORG" is indicated>

(1) by pulling the main unit fully toward you (2) by changing R ⇄ L (3) by pressing the safety stopper

<"RTN TO ORG ALL" is indicated>

(1) by pressing the  switch (2) by pressing the  switch (3) by turning ON the power



- 17. To measure for the next patient, return to Step 4 (p. 4-3).**
- 18. To finish the intraocular pressure measurement, turn OFF (○) the power switch.**
- 19. Check and clean the air-nozzle.**

See “4.5.1 Cleaning the air nozzle” (p.4-19).
- 20. Cover the instrument with the attached dust cover.**

4.3 Errors during Measurement

If the measurement is not performed correctly for a specific reason, an abbreviated error message appears and blinks for several seconds.

In this case, eliminate the error following the instructions below.

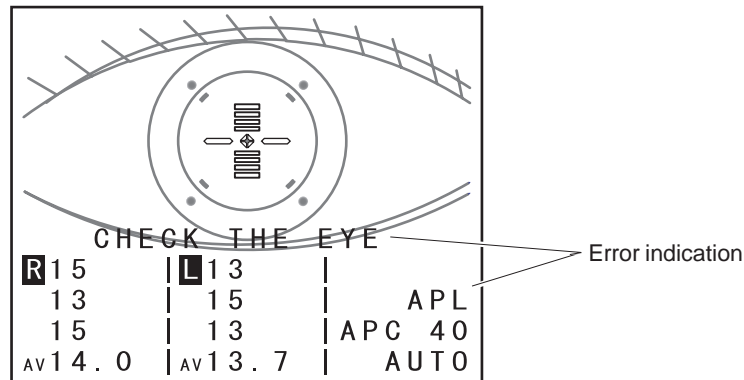

(1) APL: Applanation error

As the eyelid was not opened enough, applanation** was not proper.

- ➔ Instruct the patient to open his/her eyes wider. If he/she cannot do so, let an assistant open the eyelids wider by using a swab, etc..

(2) ALM: Alignment error

Alignment** is not proper.

- ➔ Perform the alignment and the measurement again.

(3) BLK: Blinking and slight movement of the eye

Measurement is impossible because of blinking and slight movement of the eye.

- ➔ Instruct the patient not to blink or move the eye until measurement is finished. After the blinking and slight movement stop, perform the measurement again.

(4) OVR: Over the measurement range

The intraocular pressure exceeds the measurement range of the present setting.

- ➔ Change the measurement range to "APC 60" or "60". Then perform the measurement again.

(5) PCE: APC error

The patient's eye cannot be measured with the air pressure which is controlled by the APC function because of considerable fluctuation of the intraocular pressure.

- ➔ Change the measurement range from "APC 40" to "40" or from "APC 60" to "60". Then perform the measurement again.

4.4 Setting and Operation of the Sub-switches

The sub-switches under the cover set the following conditions:

- Cancel/set of the eyelid detection mode**
- Set of the test mode**, measurement mode and parameter setting mode.

This section describes the setting and operation of each sub-switch.

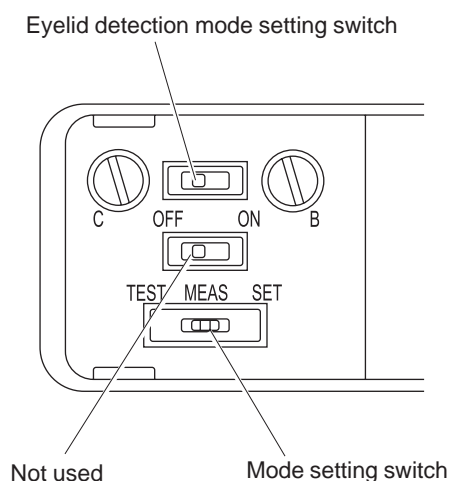

4.4.1 Eyelid detection mode

With this mode, the instrument always checks the condition of the opening of the eye and the auto-measurement is performed only when the eyelid is opened enough.

(1) Setting and cancelling of the eyelid detection mode

Setting and cancelling is performed by sliding the eyelid detection mode setting switch to the right or left.

- Sliding it to the ON side → Eyelid detection mode is set. (Factory setting)
- Sliding it to the OFF side → Eyelid detection mode is cancelled.

(2) About the eyelid detection mode

When the eyelid detection mode is set, the opening of the eye is checked by the eyelid detection lights in the figure on the right. (When the eyelid is over the applanation area, the detection lights disappear.)

The measurement starts automatically when the eyelid is opened enough and the alignment** and the focusing** are completed.

If the eyelid is not opened enough, “OPEN THE EYE WIDER” appears on the screen to inform the operator that the measurement will not start automatically.

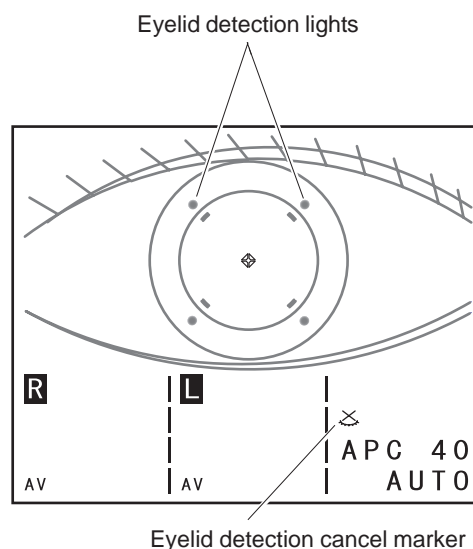

- * When the eyelid detection mode is cancelled, frequent occurrence of measurement error and fluctuations of measurement data is expected. Therefore, it is recommended to cancel this mode only when it is difficult to perform the measurement using the eyelid detection mode. When the eyelid detection mode is cancelled, the eyelid detection cancel marker “⊗” appears on the screen.





4.4.2 Test mode

In order to maintain the accuracy of the measurement, the test mode is used by checking the pressure of puffed out** air.

NOTE

- Before starting the test mode**, confirm that there is nothing in front of the air-nozzle. An obstruction may interfere with proper checking of the air pressure.

1. Press the  switch to set the measurement range to “40”.
2. Open the cover for the sub-switches and slide the mode setting switch to the left (TEST).
3. Press the start button to puff out air.

① “PRESSURE TEST OK”	→	The air pressure is normal.
② “  ” is indicated	→	The instrument is in the standby mode. Wait until “  ” disappears and press the start button once again.
③ “PRESSURE PEAK ERROR” “PRESSURE SLOPE ERROR” “NO PRESSURE UP”	→	Turn the power switch OFF (○) once and ON () again. Wait until “  ” disappears and perform the test again. If any of the three errors occurs again, contact NIDEK or your authorized distributor.
4. Return the mode select switch to the center (MEAS).
5. Press the  switch to set the measurement range** to “60” and check the air pressure in the same way as steps 2 to 3.
6. After checking, return the mode selection switch to the center (MEAS) and close the cover for the sub-switches.

4.4.3 Parameter setting mode

1. Open the cover for the sub-switches and slide the mode setting switch to the right (SET).

The screen display changes as illustrated on the right. The parameters that can be changed appear four at a time.

1. DATE&TIME	2002/12/31 23:59
2. DATE FORMAT	Y/M/D
3. SLEEP	YES
4. TONE	3

2. Press the or the switch to select the parameter to be changed.

There are 17 parameters.

Every pressing of each switch changes the parameter number as follows:

 switch: “1” → “17” → “16” → ... “1” → “17” → “16” ...

 switch: “1” → “2” → “3” → ... “16” → “17” → “1” ...

3. Change the setting of the selected parameter.

Change the parameter setting with the start button or the joystick.

(The items that can be changed blink.)

* In the explanation of the parameters below, the parameters with “” are the factory settings.

(1: DATE & TIME) Setting of the year, month, date, hour, and minute (in 24-hour format)

Start button → Every pressing of this button changes the items that can be changed in the following order:

Year → Month → Day → Hour → Minute → Year → ...

Joystick → Turning it clockwise increases the number. Turning it counterclockwise decreases the number.

(2: DATE FORMAT) Setting of the format of date and time for the printout (factory setting: )

Joystick → Turning it clockwise changes the format in the following order:

Y/M/D → M/D/Y → D/M/Y → Y/M/D → ...

Turning it counterclockwise changes the format in the reverse order.

* Y, M, and D represent year, month, and day respectively.

4 - 15

- (3: SLEEP) Setting of enabling or disabling the monitor auto OFF function. (factory setting: YES)
- Joystick → Turning it clockwise sets the parameter to “YES (enable)”. Turning it counterclockwise sets the parameter to “NO (disable)”.
- * In the monitor auto OFF function, all screen displays disappear after five minutes of inactivity.
- (4: TONE) Setting of the volume of the beep sounds. (factory setting: 3)
- Joystick → Turning it clockwise sets the parameter in the order of “0 (silent)” → “1” → “2” → “3 (maximum)” → “0 (silent)” → Turning it counterclockwise sets the parameter in the reverse order.
- (5: SET PATIENT NO.) Setting of printing or not printing the patient number. (factory setting: NO)
- Joystick → Turning it clockwise sets the parameter to “YES (printing)”. Turning it counterclockwise sets the parameter to “NO (not printing)”.
- (6: PATIENT NO.) If “YES” is set for “5: SET PATIENT NO.”, the patient number to be printed is set. (factory setting: 0001)
- Joystick → Turning it clockwise sets the parameter in the order of “0001 (minimum)” → ... → “9998” → “9999 (maximum)” → “0001 (minimum)” → ... in increments of 1. Turning it counterclockwise sets the parameter in the reverse order.
- * The patient number increases from the set number in increments of 1 with every printout of the measurement values.
- (7: SET LOW CONFIDENCE) Setting of displaying or not displaying the low confidence data**. (factory setting: NO)
- Joystick → Turning it clockwise sets the parameter to “YES (displaying)”. Turning it counterclockwise sets the parameter to “NO (not displaying)”.
- (8: LOW CONFIDENCE LV.) If “YES” is set for “7: SET LOW CONFIDENCE”, displaying or not displaying the level of the low confidence data is set. (factory setting: NO)
- Joystick → Turning it clockwise sets the parameter to “YES (displaying)”. Turning it counterclockwise sets the parameter to “NO (not displaying)”.
- * If “YES” is set, the level is displayed from “*3” to “*1”. The smaller the number is, the lower the confidence of the data becomes. If “NO” is set, “*” is displayed regardless of the level of confidence.

(9: FIX LED BLINK) Setting of blinking or not blinking of the fixation light. (factory setting: YES)

Joystick → Turning it clockwise sets the parameter to “YES (blinking)”. Turning it counterclockwise sets the parameter to “NO (not blinking)”.

(10: AUTO SHOT) Setting of starting or not starting the measurement with the auto shot. (factory setting: YES)

Joystick → Turning it clockwise sets the parameter to “YES (auto shot is enabled)”. Turning it counterclockwise sets the parameter to “NO (auto shot is disabled)”.

* The auto shot is puffing out** air for the measurement when the alignment with and focusing on the patient’s eye becomes proper.

(11: MEASUREMENT COUNT) Setting the number of measurements for an eye. (factory setting: 3)

Joystick → Turning it clockwise increases the number from 3 to 10 at the maximum in increments of 1. Turning it counterclockwise decreases the number to 3 at the minimum in increments of 1.

* If “YES” is set for “7: SET LOW CONFIDENCE”, low confidence data** are included in the measurement number.

* Do not change this parameter during the measurement.

(12: AUTO PRINT (COM)) Setting of printing and data communication or not printing or no data communication when the number of measurements set for “11: MEASUREMENT COUNT” are finished for both eyes. (factory setting: NO)

Joystick → Turning it clockwise sets the parameter to “YES (printing or data communication)”. Turning it counterclockwise sets the parameter to “NO (not printing or no data communication)”.

(13: PRINT SW) Setting which of printout, data communication, or both will be performed when the “” switch is pressed. (factory setting: PRINT)

Joystick → Turning it clockwise sets the parameter in the order of “PRINT” → “COM” → “PRINT&COM” → “PRINT” → ... Turning it counterclockwise sets the parameter in the reverse order.

* “PRINT”, “COM”, and “PRINT&COM” represent printout, communication, and printout and communication respectively.

(14: PRINT DENSITY) Setting of the print density. (factory setting: 3)

Joystick → Turning it clockwise makes the printout darker in the order of “1 (light)” → “2” → “3” → “4” → “5 (dark)” ... Turning it counterclockwise makes the printout lighter in the reverse order.

4 - 17 

(15: LOW CONF ALARM) Enabling or disabling the electronic sounds that are heard in the case of the low confidence error occurrence. (factory setting: **NO**)

Joystick → Turning it clockwise changes the parameter to “YES (electronic sounds are heard). Turning it counterclockwise changes the parameter to “NO (electronic sounds are not heard)”.

(16: SET COMMENT) Setting of printing or not printing the comment. (factory setting: **NO**)

Joystick → Turning it clockwise changes the parameter to “YES (printing). Turning it counterclockwise changes the parameter to “NO (not printing)”.

(17: COMMENT) Inputting the comment to be printed.

Start button → Every pressing of the start button confirms the character being displayed and makes inputting of the next letter ready.

Joystick → Turning it clockwise changes the character being displayed in the field from the top left to the bottom right of the character code table. Turning it counterclockwise changes the character in the reverse order.

* 54 characters can be input at the maximum for the comment.

SPACE	!	”	#	\$	'	()	*	+
,	-	.	/	0	1	2	3	4	5
6	7	8	9	:	;	<	=	>	?
@	A	B	C	D	E	F	G	H	I
J	K	L	M	N	O	P	Q	R	S
T	U	V	W	X	Y	Z			

4. If there are other parameters to be changed, repeat steps 2-3 and select the desired setting.

To print out the contents of the parameters, press the  switch.

5. After the setting, return the mode setting switch to the center (MEAS) and close the cover for the sub-switch.

Returning the mode setting switch to the center (MEAS) newly saves the parameter settings.

NOTE

- Do not turn OFF the power switch until the beep sounds indicating the end of the writing of data are heard. (If the power switch is turned OFF (○) before the beep sounds are heard, the parameter settings will not be saved.)

```

PARAMETERS
1. DATE&TIME      03/12/2000 04:35
2. DATE FORMAT    D/M/Y
3. SLEEP          YES
4. TONE
5. SET PATIENT NO. 3
6. PATIENT NO.    NO
7. SET LOW CONF.  0001
8. LOW CONF. LV. NO
9. FIX LED BLINK YES
10. AUTO SHOT     YES
11. MEAS. COUNT   YES
12. AUTO PRINT(COM) 3
13. PRINT SW      NO
14. PRINT DENSITY PRINT
15. LOW CONF. ALARM 3
16. SET COMMENT   NO
17. COMMENT
%#"$%$#####V
!XYXYXYXY!WYY
WYXY"$#$#"
NT-2000 VER3.00

```

4.5 Cleaning the Air Nozzle and the Pulse Detector

After measurements are completed for a day, clean the air nozzle and pulse detector. If the eye image on the screen is not clear, the glass part of the air nozzle may be dirty with dust, tears, fingerprints, etc.. If so, accurate measurement data cannot be obtained and the air nozzle needs to be cleaned following the procedures below.

4.5.1 Cleaning the air nozzle

NOTE

- During cleaning, pay attention not to let dust go into the opening of the air nozzle.

1. Check for dust and dirt by looking at the glass part of the air nozzle from an angle.
2. If there is dust, etc., blow it away with a blower.
3. Wipe the glass part lightly with a swab dipped in alcohol*8.



CAUTION

- Do not wipe the glass part without removing dust or wipe it forcefully. Wipe lightly.
The glass part may be damaged.

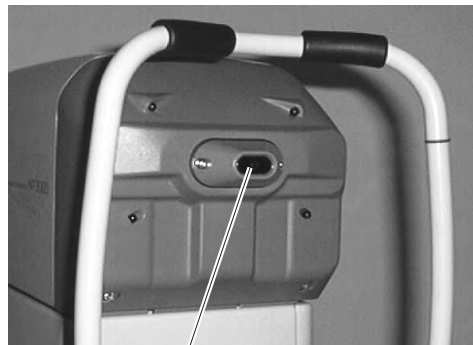

Air nozzle

4. Check if dust, etc. remains on the glass part or not.
5. If dust, etc. remains, go back to step 2. If not, this cleaning is finished.

§5 TROUBLESHOOTING GUIDE

5.1 Primary Troubles and the Countermeasures

If the instrument does not work properly, check it referring to the table below before requesting repair.

If the symptom is not eliminated, inform NIDEK or your authorized distributor of the symptom, model name (NT-2000) and serial number (see the label on the instrument).

Symptom	Cause	Suggestion
The screen does not turn ON when the power is turned ON ().	<ul style="list-style-type: none"> The power cord is not connected. The power switch is not turned ON. The fuses are blown. 	<ul style="list-style-type: none"> Connect the power cord to wall-outlet. Turn ON () the power switch again. Check the fuses. If they are blown, replace them with new ones.
The screen does not turn ON though the instrument is powered ON.	<ul style="list-style-type: none"> Monitor auto-OFF function is activated. The brightness adjustment is not correct. 	<ul style="list-style-type: none"> If the memory lamp is blinking, press any switch. Adjust the brightness using the control panel under the cover for the sub-switches.
The screen suddenly turns OFF.	<ul style="list-style-type: none"> Monitor auto-OFF function is activated. The fuses are blown. 	<ul style="list-style-type: none"> If the memory lamp is blinking, press any switch. Check the fuses. If they are blown, replace them with new ones.
The main unit cannot be moved horizontally.	<ul style="list-style-type: none"> The locking knob is set to LOCK or BRAKE. 	<ul style="list-style-type: none"> Cancel the LOCK or BRAKE of the locking knob.
Printing out cannot be performed.	<ul style="list-style-type: none"> The printer paper has run out. The printer paper is jammed. The measurement data are deleted. 	<ul style="list-style-type: none"> Check the printer paper. If it has run out, set the new paper. If the printer paper is jammed, remove it. Check whether the measurement data are memorized or not in the instrument by looking at the memory lamp.
Though the printer is working, nothing is printed on the paper.	<ul style="list-style-type: none"> The printer paper is set upside down. The printer head is damaged. 	<ul style="list-style-type: none"> Reverse the printer paper. If the symptom cannot be improved, contact NIDEK.
The printed characters are imperfect.	<ul style="list-style-type: none"> The printer head is damaged. 	<ul style="list-style-type: none"> Contact NIDEK.
The characters' positions on the screen are shifted.	<ul style="list-style-type: none"> The backup battery is dead. 	<ul style="list-style-type: none"> Contact NIDEK.
The printed date, time and patient No. are not correct.	<ul style="list-style-type: none"> The backup battery is dead. 	<ul style="list-style-type: none"> Contact NIDEK.

5.2 Error Messages and the Countermeasures

If a message in the table below is displayed, check it referring to the countermeasures in the table. After that, inform NIDEK or your authorized distributor of the message number, the model name of the instrument (NT-2000), and the serial number (on the label on the instrument).

Message No.	Message	Cause and countermeasure
ERR1	ERR1:EEPROM ERROR	The cause may be turning OFF of the power during writing of the data in the EEPROM or failure of the main board or the EEPROM on the main board. If turning ON the power again displays the same message, turn OFF the power and contact NIDEK or your authorized distributor.
ERR2	ERR2:BATT ERROR	The cause may be that the battery has run out of power or failure of the main board or the Real Time Clock on the main board. Turn OFF the power of the instrument and contact NIDEK or your authorized distributor.
ERR3	ERR3:ERROR Y	The cause may be failure of the up and down movement motor, the position detection board, or the driver board, or break of the cable. Turn OFF the power of the instrument and contact NIDEK or your authorized distributor.
ERR4	ERR4:ERROR X	The cause may be failure of the right and left movement motor, the position detection board, or the driver board, or break of the cable. Turn OFF the power of the instrument and contact NIDEK or your authorized distributor.
ERR7	ERR7:CAMERA ERROR	The cause may be failure of the CCD camera, break of a wire or failure of the main board. Contact NIDEK or your authorized distributor.
ERR8	ERR8:PISTON ERROR	The cause may be locking of the piston, failure of the solenoid position sensor, break of a wire, or maladjustment. Pressing the start button of the joystick during the occurrence of the PISTON error drives the piston with a stronger power than usual. Locking of the piston may be cleared. If the message does not disappear by pressing the start button, turn OFF the power of the instrument and contact NIDEK or your authorized distributor.
ERR9	ERR9:CHARGE ERROR	The cause may be failure of the transformer or the driver board, or break of the cable. Turn OFF the power of the instrument and contact NIDEK or your authorized distributor.
ERR10	ERR10:RAM ERROR	The cause may be failure of the main board. Turn OFF the power of the instrument and contact NIDEK or your authorized distributor.
ERR11	ERR11:CHECKSUM ERROR	The cause may be failure of the main board. Turn OFF the power of the instrument and contact NIDEK or your authorized distributor.

Message No.	Message	Cause and countermeasure
WRN1	WRN1:PRINT ERROR	The printer paper has run out or the lever of the printer head is left raised. Replace the printer paper or check the position of the lever of the printer head. If printout can be performed normally, the message disappears.
WRN2	WRN2:COM ERROR	The external communication was not performed normally. Perform communication again. If communication can be performed normally, the message disappears.
WRN3	WRN3:MOVEMENT ERROR	During use of the instrument, the measuring unit was raised and the SAFE switch worked. Turn ON the power of the instrument again.
WRN4	WRN4:PARAMETER ERROR	When checksum of the parameter saving area was performed, the checksum was different. Turn ON the power of the instrument again.
WRN5	WRN5:PRES ERROR	In the test mode of the air pressure, an error was detected in the rise, peak, or slope of the signal. The cause may be failure of the solenoid or the air pressure sensor, or maladjustment of the piston. Turn OFF the power of the instrument and contact NIDEK or your authorized distributor.

* The messages that begin with “WRN” disappear by pressing the “” switch.

§6 MAINTENANCE



NOTE

- If the instrument is sent back to NIDEK for service, it will be cleaned as described in 4.5 and 6.4. Furthermore, internal dust and dirt on the optical parts will be removed, and the appearance and internal parts of the instrument will all be in good condition.

6.1 Replacing the Printer Paper

If the printer paper is running short, a red line appears on both sides of the printer paper. Stop the printer and replace the paper with a new roll.

⚠ CAUTION

- Never press the  switch when the printer paper is not set in the printer. The printer head may be damaged.
- For advancing the printer paper, press the  switch when the memory lamp is not lit. Pulling the printer paper forcibly may damage the printer head.

1. Pull the printer cover toward yourself.



2. Raise the right lever to move the printer head off the printer paper. Then turn the right gear toward the instrument to rewind the printer paper.

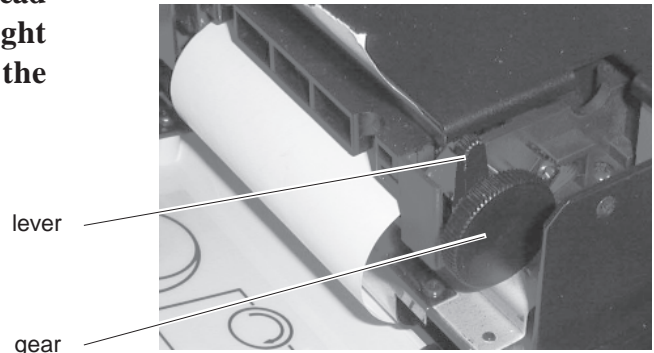

- 3. Remove the used printer paper and pull out the roller pivot.**



- 4. Insert the roller pivot into the new printer paper roll.**

NOTE

- Be careful about the direction that the printer paper is set. Otherwise, the data cannot be printed out.

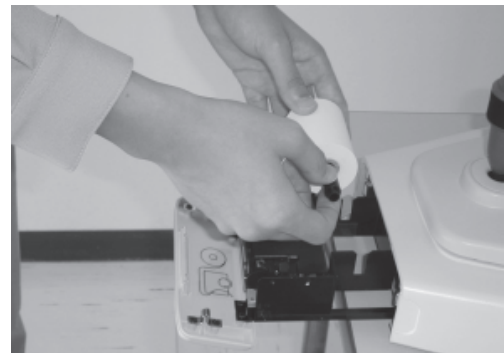

- 5. Cut the end of the printer paper straight with scissors and pass the paper through the printer as the arrow in the figure on the right shows.**

When the paper reaches the point “@”, turn the gear toward yourself to feed the paper.

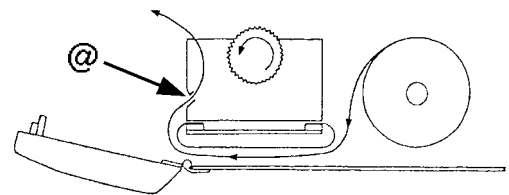

- 6. Adjust the position of the printer paper and lower the lever to move the printer head onto the printer paper. Then pass the paper through the printer cover.**

To remove the slack in the roll, turn the gear toward the instrument.

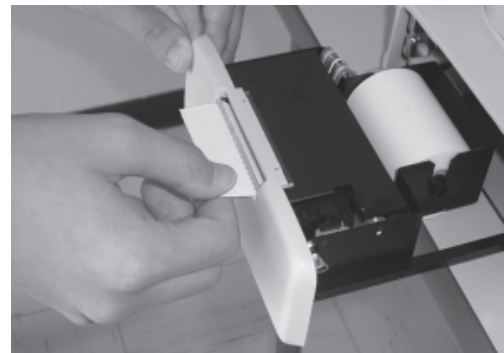

- 7. Close the printer cover by pushing it.**

Cut extra paper hanging from the printer cover using the cutting edge.



6.2 Replacing the Fuses

If the power is not supplied to the instrument by turning the power switch ON (|), the fuses may be blown. Replace the fuses with the new ones according to the procedures below.

1. Turn OFF (O) the power switch and disconnect the plug of the power cord from the outlet.
2. After locking the main unit to the base with the locking knob, lay down the instrument gently.
3. Remove the fuse carrier with a flatblade screwdriver.

While pressing the fuse carrier inward, rotate it in the direction shown in the figure on the right.

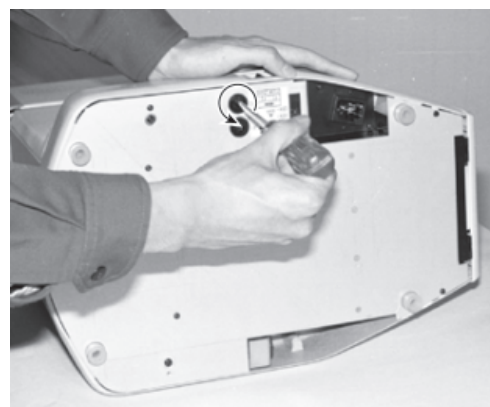

4. Replace the old fuses in the fuse carrier with the new ones.
5. Lock the fuse carrier to the fuse holder by using a flatblade screwdriver.

While pressing the fuse carrier inward, rotate it in the opposite direction from the time of removal.



6. Check the operation of the instrument.

Insert the plug of the power cord into the outlet and turn ON (|) the power switch. At this time, check if the screen is also turned ON.

CAUTION

- Be sure to use the correct fuses specified on the label beside the fuse holder. When replacing the fuses, be sure to replace both of them with new ones.
If the wrong fuses are used, the instrument may malfunction and may cause a fire.
- If the new fuses blow soon after replacement, contact NIDEK or your authorized distributor.

6.3 Attaching the Chinrest Paper

1. Extract the two pins from the chinrest.
2. Take an appropriate amount of the chinrest paper from the pack.

The thickness of the chinrest paper sheets should be approximately 6mm or less.

3. Insert the two pins into the holes of the chinrest paper.
4. Attach the chinrest paper to the chinrest.

While holding the sheets of chinrest paper and the two pins together, insert one pin into one of the holes of the chinrest.

Insert the other pin into the other hole of the chinrest.

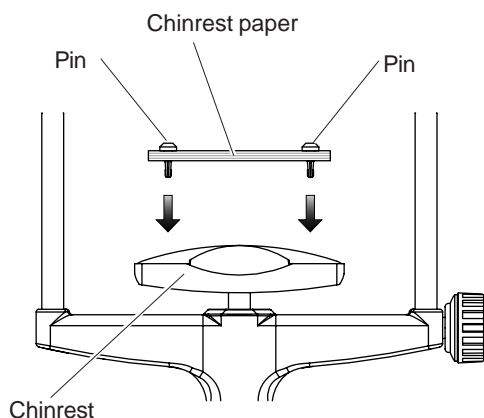

6.4 Cleaning the Exterior

Wipe the cover and screen with a soft cloth when they get dirty.

For stubborn dirt, immerse the cloth in a detergent diluted with water, wring it, and wipe to remove the dirt. After cleaning, wipe them with a dry soft cloth.

For parts that will be touched by a large number of people, such as the forehead rest, chinrest, etc., wipe them with clean gauze or absorbent cotton dipped in rubbing alcohol.

CAUTION

- Do not use organic solvents (thinner, etc.) or cleaners containing abrasives. The surface or paint of the housing may be damaged.

6.5 Consumables and Maintenance Parts List

Part Name	Unit for order	Order No.
Printer paper	1 box (3 rolls)	806-20-00001
Chinrest paper	1 pack (100 pieces of paper)	32903-M047
Fuse AC250V T1A (AC 100V, 115V)	2	804-02-02039

§7 SPECIFICATIONS AND COMPOSITION

7.1 Specifications

1. Measurement

1-1. Measurement range:	1 to 60 mmHg (1 mmHg increments)
1-2. Measurement range setting:	APC 40 (1 to 40 mmHg) APC 60 (1 to 60 mmHg) 40 (1 to 40 mmHg) 60 (1 to 60 mmHg)
1-3. Measurement distance:	11mm

2. Alignment

2-1. Alignment method:	1 alignment spot + focusing indicator		
2-2. Inner fixation light:	Green LED		
2-3. Operation range by joystick:	Back and forth 36mm Right and left 86 mm Up and down 28 mm		
2-4. Operation range by joystick:	(Alignment)	(Focus)	(Airpuffing)
	(AUTO) Auto	Manual	Auto
	(MANUAL) Manual	Manual	Auto

3. Display

3-1. Screen:	5-inch TFT LCD
--------------	----------------

4. Printouts

4-1. Printer:	Thermal line type
4-2. Data to be printed:	(Normal format) Date and time (year, month, day, time, 24 hours) Measurement value (10 measurement values for each eye at the maximum) Average (Average of displayed data)

5. Interface function

5-1. Function:	Provided
5-1. Standard:	RS232C

6. Power source

6-1. Voltage:	100, 115 Vac \pm 10%
6-2. Frequency:	50/60 Hz
6-3. Capacity:	70 VA (maximum)

7. External view

7-1. Dimension: 260 (W) × 487 (D) × 457 (H) mm (excluding protrusions)
7-2. Weight: Approx. 17kg

8. Environment

8-1. In use: Temperature: 10 to 40°C (50 to 104 °F)
Humidity: 30 to 85% (non-condensation)
8-2. In storage/transport: Temperature: -20 to 60°C (-4 to 140 °F)
Humidity: 10 to 95% (non-condensation)
8-3. Others: Little dust

7.2 Standard Configuration

- Main body 1
- Fuses 4 (2 are set in the main body)
- Printer paper 4 rolls (1 is set in the main body)
- Chinrest paper 1 pack (100 sheets)
- Fixing pins for chinrest paper 2
- Power cord 1
- Dust cover 1
- Operator's manual 1

7.3 Options

- Interface cable (D-sub, 25 pin, 2m) 18535-EA95
- Interface cable (D-sub, 9 pin, 2m) 18535-EA96

- **Alignment**

To align the corneal center of the patient's eye with the air nozzle for measurement.

- **Alignment mode**

A mode to perform alignment.

There are two kinds of modes:

“Auto-alignment”

The instrument automatically performs alignment.

“Manual alignment”

The alignment is performed by using the joystick

NT-4000 has three methods of alignment.

“F.AUTO” (=Full auto) .. Alignment and focusing are performed automatically.

“S.AUTO” (=Semi auto) Only alignment is performed automatically.

“MANUAL” (=Manual) . Alignment is performed using the joystick.

- **APC (Automatic Puff Control)**

The function which performs the normal measurement for the first time, however, in the subsequent measurement, automatically controls the air pressure in order to measure using a softer puff of air.

- **Automatic shut-off function**

When measurement is finished, this function activates to stop puffing out air to eliminate extra puffing. With this function, uncomfortableness is decreased.

- **Applanation**

To flatten the cornea by pressing it with air pressure.

- **Eyelid detection mode**

The mode which is always checking the condition of the opening of the eye and allows for auto-measurement only when the eye is opened enough.

It is recommended to select this mode for normal measurement. (See p. 4-20.)

- **Focusing indicator**

The indicator which shows the distance between the corneal center of the patient's eye and the tip of the air-nozzle.

It varies according to the distance. (See p.3-5, 3-6, 4-6.)

- **Focusing**

To keep the best distance between the corneal center and tip of the air nozzle after alignment. (both center of the cornea and air nozzle are aligned).

- **Low confidence data**

The measured data with “*”.

It appears on the screen when measurement is performed in spite of a measurement error. (APL or ALM). As the confidence of the measured data is low, this kind of measured data is called “Low confidence data”.

- **Measurement range**

The range that the measurement can be performed. There are four kinds of measurement ranges: “APC 40”, “APC 60”, “40”, “60” so that most the accurate measurement can be performed in the suitable condition for the intraocular pressure of the patient and its fluctuation.

Normally, select “APC 40” or “APC 60”.

- **Proper alignment**

It means that both alignment and focusing are in the ideal condition. In this case, “” appears on the screen.

- **Puff out**

To blow out air onto the cornea of the patient’s eye for measurement or to blow out air. The pressure used for applanation is called “air pressure” in this manual.

- **Pulse detection mode**

With this mode, the measurement is performed in synchronization with the pulse signal (pulse wave) that is obtained from the patient’s forehead.

- **Safety space**

The space kept by the safety stopper so that the tip of the air nozzle does not touch the cornea.

Normally, the safety space is 7 - 8mm.

- **Test mode**

The mode for the test to maintain accuracy of the measurement.

It checks the air pressure of the air which is puffed out.